

# HERMETIC SEALED DC CONTACTOR

## EVH400

(H: 1500V Class)



**Application (응용분야)** : Charging System, Battery Energy Storage System, Solar System, Fuel Cell Vehicle, etc.

### Magnet coil ratings (코일정격)

Nominal voltage(V)	Item	Inrush Coil current 150ms (Max.)	Holding Coil current	Pick-up voltage (V) max.	Drop-out voltage (V) min.	Holding voltage (V) min.	Max. voltage (V)	Remark
12S	12V	2.6A	0.45A	9VDC	6VDC	7.5VDC	18VDC	PWM economizer
24S	24V	1.4A	0.20A	18VDC	12VDC	15.0VDC	32VDC	
AS	12 to 36V	2.6A	0.15 to 0.45A	9VDC	6VDC	7.5VDC	36VDC	
12D	12V	4.4A	0.4A	9VDC	6VDC	7.5VDC	18VDC	Double coil economizer
24D	24V	2.6A	0.3A	18VDC	12VDC	15.0VDC	32VDC	

Notes : 1. Nominal current and coil resistance are measured at +20°C. 2. Differences of coil resistance are ±10%.  
3. Performance characteristic coil temperature is measured at +20°C.

### Contact ratings (접점정격)

Item	Type	1 Pole Resistor load
		EVH400
Max. Continuous current (wire size 300mm <sup>2</sup> )		400A
Max. switching current		500VDC 900A
		1000VDC 600A
Contact rating switching voltages		12 to 1500VDC
Max. cut-off current		400VDC 2000A 10 Ops.
Voltage drop across contacts per 100A		30mV Max. (At 5VDC)
Min. permissible load		12VDC 0.5A
Description		S.P On/Off (a)
Contact Arrangement, auxiliary contacts		1Form A (SPST-NO.)
General Aux, Contact Current, Max.		2A 30VDC / 3A 125VAC
General Aux, Contact Current, Min.		100mA 8VDC
Gold alloy Aux, Contacts Max. (Low level circuit type)		0.1A 30VDC / 0.1A 30VAC
Gold alloy Aux, Contacts Min. (Low level circuit type)		1mA 5VDC / 1mA 5VAC

### Ordering information (주문방법)

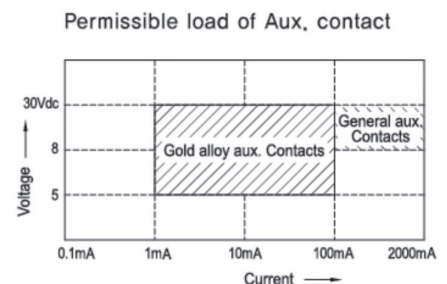
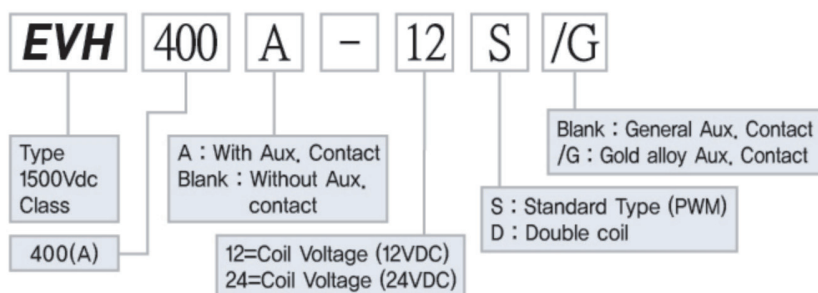

# HERMETIC SEALED DC CONTACTOR

## EVH400

(H: 1500V Class)

### Characteristics (성능)

Expected life	Mechanical (Min.)		5×10 <sup>5</sup>
	Electric (Min.) (Resistor)	750VDC 400A	6×10 <sup>3</sup>
		1000VDC 400A	1×10 <sup>3</sup>
		1000VDC 200A	1×10 <sup>4</sup>
		1500VDC 200A	2×10 <sup>3</sup>
Initial insulation resistance			Min. 200MQ 1000VDC
Initial breakdown voltage	Between open contacts		4500VAC 60 Sec. 5mA
	Between contacts & coil		4500VAC 60 Sec. 5mA
Operate time (at 20°C)			Max. 40ms
Release time (at 20°C)			Max. 10ms
Shock resistance	Functional		Min. 196 m/s <sup>2</sup> {20G}
	Destructive		Min. 490 m/s <sup>2</sup> {50G}
Vibration resistance	Functional		196 m/s <sup>2</sup> {20G} 80 to 500Hz
	Destructive		196 m/s <sup>2</sup> {20G} 80 to 500Hz
Conditions for operation transport and storage	Ambient temperature		-40°C to +85°C
	Humidity		5 to 85% R.H.
Unit weight	PWM		950g
	Double coil		1000g

### Reference data (특성곡선)

#### 온도상승곡선

- 통전시간의 최대치 Max. Current capacity
- Max. Continuous thermal current rating (amperes)

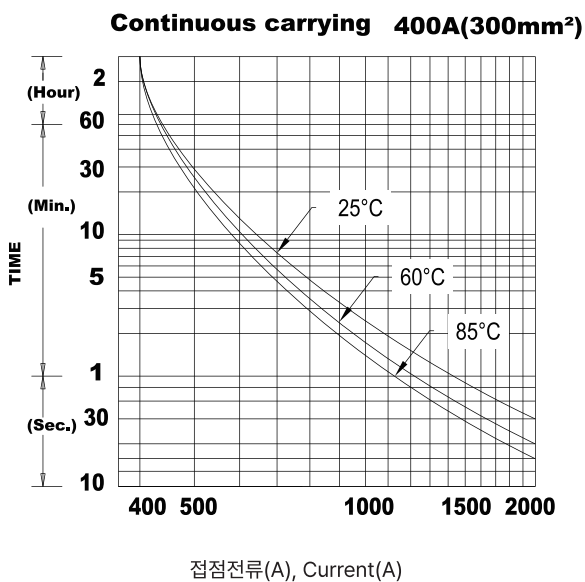

#### 전기적 수명 곡선

(Estimated Switching Ratings)

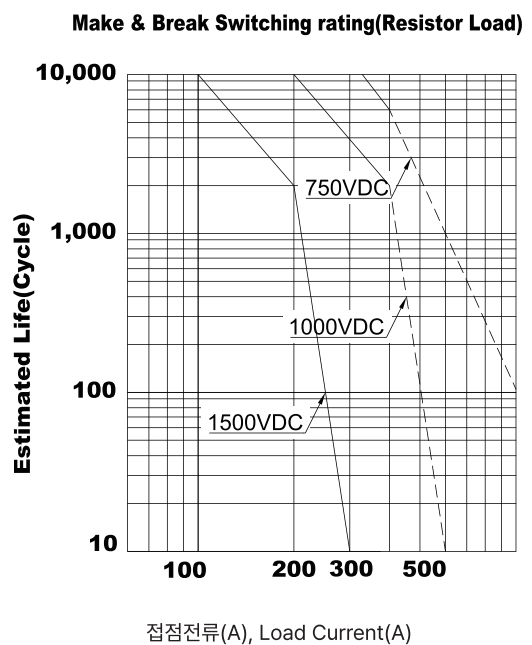



Dimension in mm (외형치수도)

Tolerance(공차) : 10mm 이하±0.3, 10~50mm ±0.6, 50mm 이상±1.0

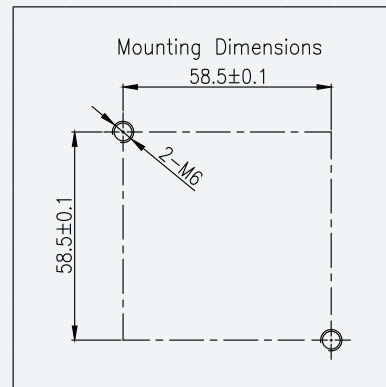
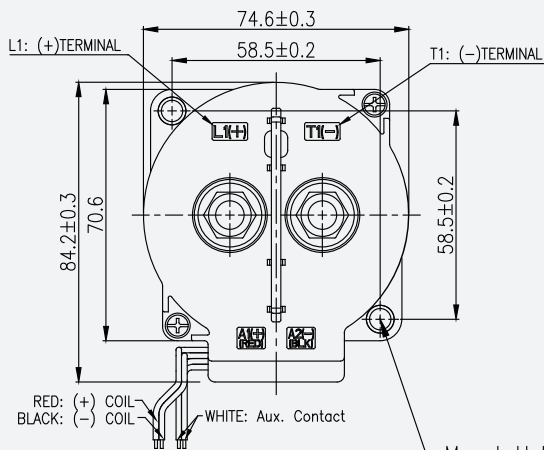

Mount Hole(∅6)  
3.1~4.0N.m(31.6~40.8kgf.cm)

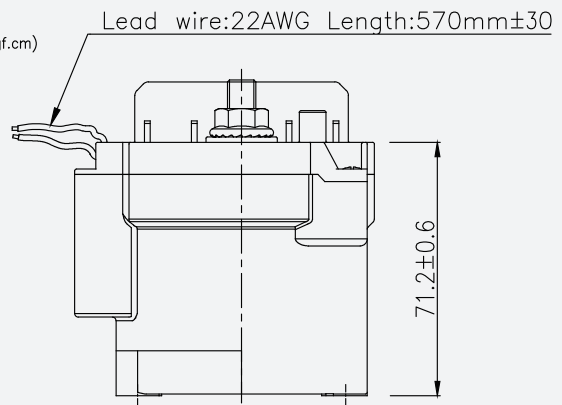
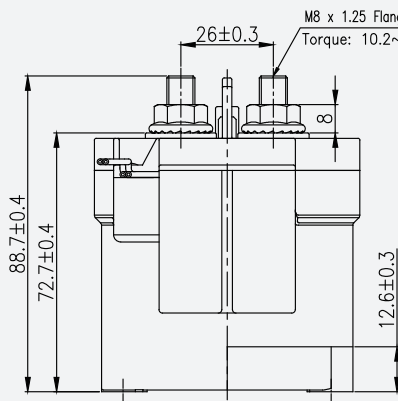

Schematic (Top View)

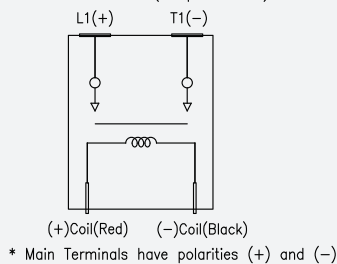

\* Main Terminals have polarities (+) and (-)