

REC45 SERIES

High Voltage Contactors

500A CONTINUOUS DUTY

1000V SYSTEM VOLTAGE



FEATURES

SPST Normally Open High Voltage Contactors

- Hermetic seal with gas fill
- Optional auxiliary contacts – for main position feedback
- Integrated coil economizer to reduce coil holding power
- Meets RoHS 2011/65/EU
- CE certified
- UL recognized (File E536110). 
- Please refer to UL file for specific part numbers that are recognized



PERFORMANCE

TABLE 1. SPECIFICATIONS				
CHARACTERISTIC		MEASURE		
Contact Arrangement		Form X, SPST NO		
Max Switching Voltage		1,000 VDC		
Dielectric Withstand Voltage Contacts to Coil		4,300 VDC, 1 minute		
Dielectric Withstand Voltage Across Open Contacts		4,300 VDC, 1 minute		
Continuous Current (2 x 127mm ² conductor)		500A		
Overload Current	1 minute	1,000A		
	5 Minutes	650A		
Make and Break		See table		
Max Short Circuit Current		7,000A @ 3ms, 3,000A @ 1s		
Min Insulation Resistance		1,000 MΩ @ 1,000VDC		
Contact Resistance		0.25mΩ (max) / 0.15mohm (typical) at 300A		
Operate Time (Max, incl bounce)		25ms		
Release Time (Max)		10ms (max) / 5ms (typical)		
Shock - Functional, 1/2 Sine, 11ms		20G		
Shock - Destructive, 1/2 Sine, 11ms		50G		
Operating Temperature		-40°C to 85°C		
Ingress Protection		Exceeds IP69, (Hermetically sealed)		
Mechanical life		500,000		
AUXILIARY CONTACTS		MEASURE		
Contact Arrangement		SPST		
Continuous Current		2A		
Minimum Current		1mA @ 12V		
COIL (all data at 20°C ambient)		J	A	B
Coil Type		PWM (economized)	Single (continuous duty)	Single (continuous duty)
Nominal Voltage		9-36 VDC	12V	24V
Pick-up Voltage (Max)		9 VDC	9 VDC	18 VDC
Drop-out Voltage (Min)		6 VDC	1.2 VDC	2.4 VDC
Inrush Current (Max), 130ms max duration		3.8A	0.5A	0.25A
Coil Resistance		3.2Ω	24 Ω +/- 7%	96 Ω +/- 7%
Holding Current		0.17A @ 12 VDC	0.50A @ 12 VDC	0.25A @ 24 VDC

Current Carry

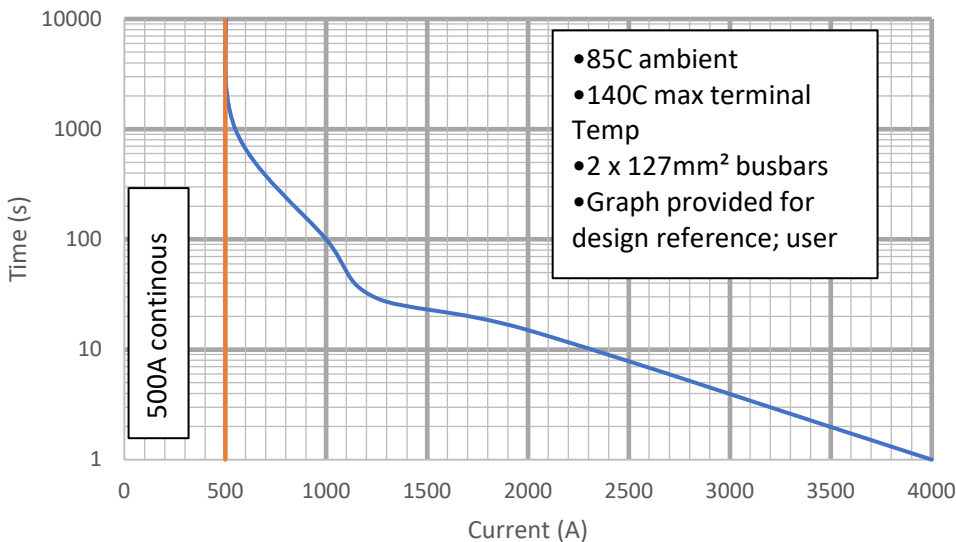

TABLE 2. RESISTIVE LOAD SWITCHING (MAKE / BREAK DATA)		
VOLTAGE	CURRENT	CYCLES
450V	250A	10,000
600V	400A	5,500 (BREAK ONLY)
800V	300A	4,000 (BREAK ONLY)
800V	200A	10,000
1000V	100A	10,000

OPTIONS

TABLE 3. PRODUCT NOMENCLATURE

	CONTACT POLARITY	MOUNTING	COIL	AUXILIARY CONTACTS
REC45	B Bi-directional	1 Bottom mount, M8 external	J 9-36V integrated PWM	X None
	P Polarity Sensitive	5 Bottom, M8 internal	A 12V single coil	A Normally Open
			B 24V single coil	B Normally Closed

PRODUCT DIMENSIONS [mm]

TABLE 4. DIMENSIONAL AND INSTALLATION

CHARACTERISTIC	MEASURE
Weight	≈ 385g (0.85 lb)
Mounting Position	Any / Not Position Sensitive
Package Quantity	30 pieces
Install Torque	9-11Nm (80-97 in-lb)
M8 Main Terminals	2-4 Nm (17-35 in-lb)
M5 Mounting Inserts	2-4 Nm (17-35 in-lb)



Mounting Style 1 – Bottom mount with M8 external threading

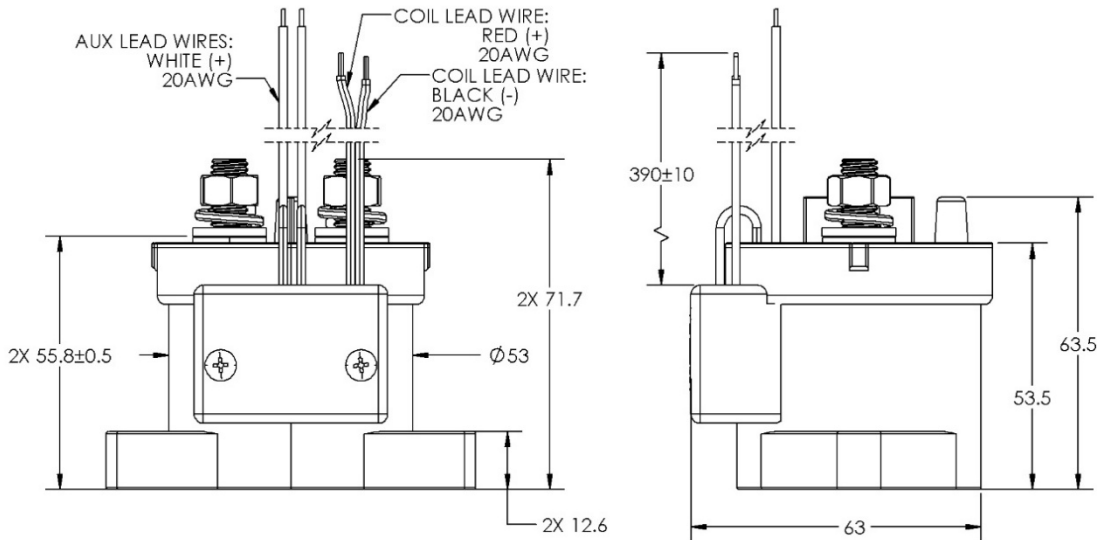
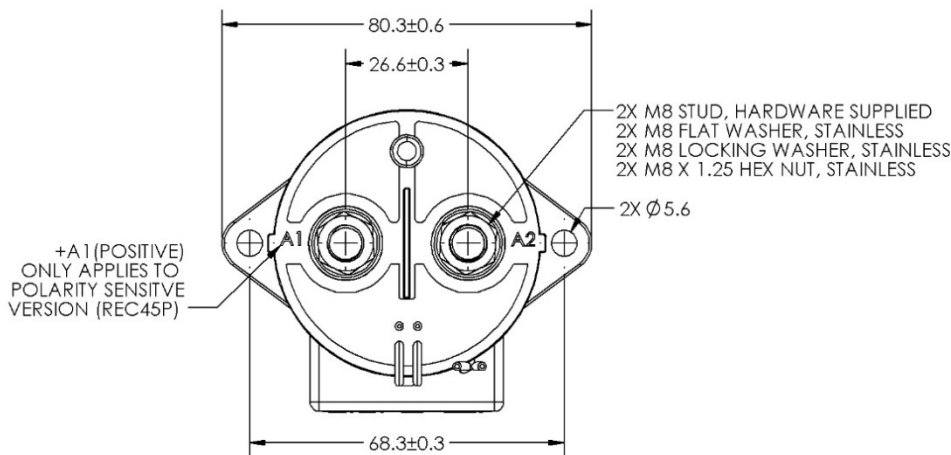

GENERAL TOLERANCES
 <10mm: ±0.3mm
 10-50mm: ±0.6mm
 >50mm: ±1.0mm

PRODUCT DIMENSIONS [mm]

Mounting Style 5 – Bottom mount with M8 internal threading



TABLE 4. DIMENSIONAL AND INSTALLATION	
CHARACTERISTIC	MEASURE
Weight	≈ 385g (0.85 lb)
Mounting Position	Any / Not Position Sensitive
Package Quantity	30 pieces
Install Torque	9-11Nm (80-97 in-lb)
M8 Main Terminals	9-11Nm (80-97 in-lb)
M5 Mounting Inserts	2-4 Nm (17-35 in-lb)

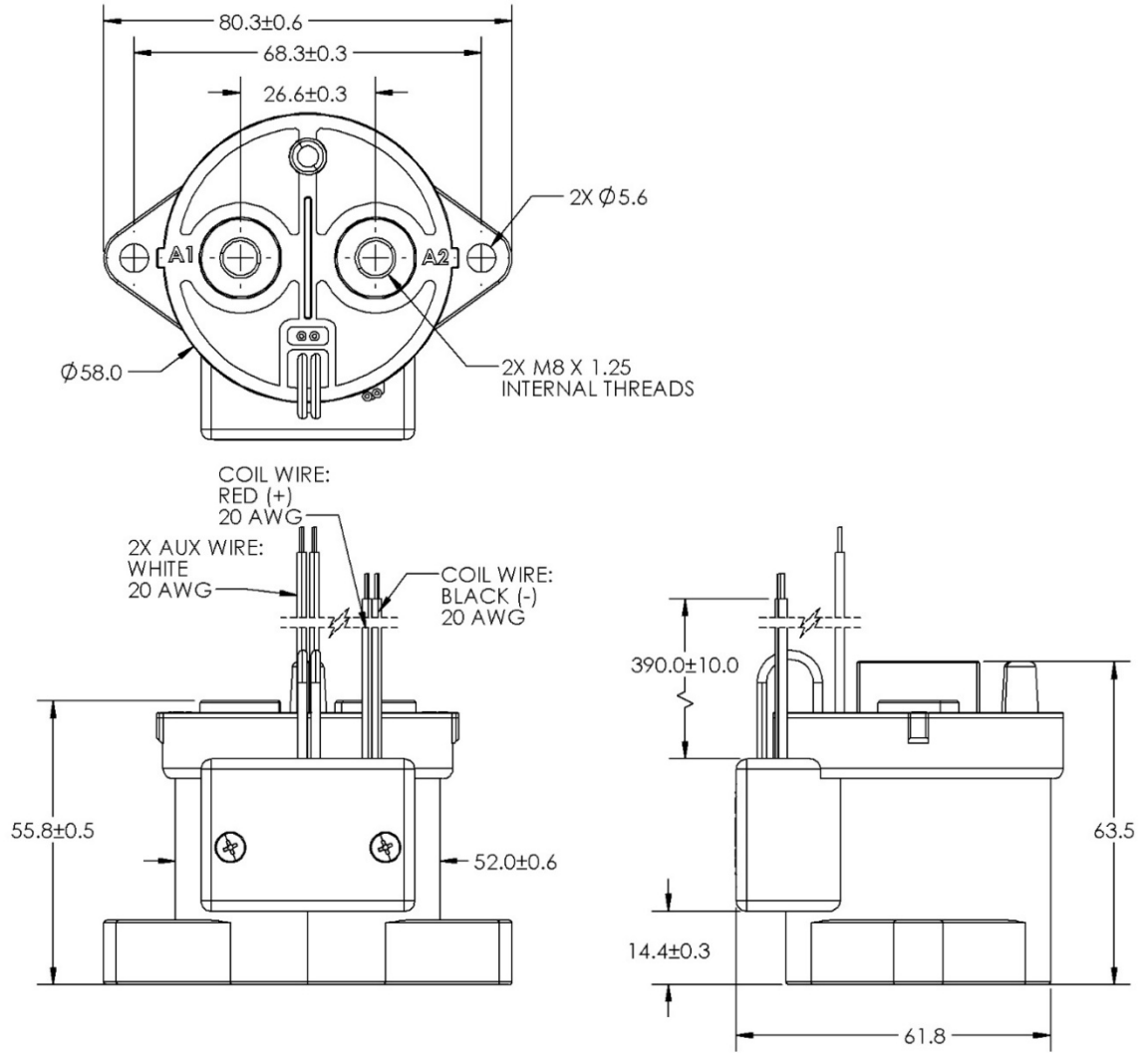

GENERAL TOLERANCES
 <10mm: ± 0.3 mm
 10-50mm: ± 0.6 mm
 >50mm: ± 1.0 mm

NOTES

- Polarity Sensitive versions are marked +A1 and -A2 for the power terminals. For applications that require the contactor to open under load, please ensure current is flowing from the +A1 to the -A2 terminal. For Bi-Directional versions the direction of current does not matter when breaking under load.
- Contactor is operated by a coil that changes resistance with temperature: Maximum coil voltage will be lower than indicated at temperatures above 25°C, and higher than indicated at temperatures below 25°C.
- Nominal Coil Voltage for Pick-up Current, Coil Current and Coil Power specifications, Current/Wattage will be lower than indicated at temperatures above 25°C and higher than indicated at temperatures below 25°C.
- Pick-up Voltage and Drop Out Voltage will be lower than indicated at temperatures below 25°C and higher than indicated at temperatures above 25°C.
- Limit terminal temperature to 140C continuous
- Attached cables and busbars directly to the main terminal pad using the recommended install torque. Do not use washers or other materials between the contactor and the conductor. This will ensure the lowest possible contact resistance.
- Avoid excessive coil voltages. Exceeding the ratings on the datasheet may result in high coil temperature and coil failure.
- Contactor may be used above Max Switching Voltage if the application does not require significant load breaking. Please contact Rincon Power to discuss in more detail.

Legal Disclaimer Notice for Rincon Power, LLC Datasheet

This legal disclaimer applies to purchasers and users of products manufactured by or on behalf of Rincon Power, LLC ("Rincon"). Unless otherwise expressly indicated in writing, Rincon's products, product specifications and data sheets relating thereto are subject to change without notice. Users should check for and obtain the latest revision information and verify that such information is current and complete before placing orders for Rincon's products. Users should always verify the actual performance of the Rincon's products in their specific systems and applications.

Except as expressly set forth in the relevant purchaser order terms and conditions or applicable agreement, Rincon makes no warranty, representation or guarantee regarding the products, expressed or implied, including, but not limited to, a warranty of merchantability or fitness for a particular purpose. To the maximum extent permitted by applicable law, Rincon disclaims (i) any and all liability arising out of the application or use of any product, (ii) any and all liability, including without limitation special, consequential or incidental damages, and (iii) any and all implied warranties, including warranties of fitness for particular purpose, non-infringement and merchantability.

In no event shall Rincon be liable for any incidental or consequential damages resulting from the use, misuse or inability to use the product. This exclusion applies regardless of whether such damages are sought based on breach of warranty, breach of contract, negligence, strict liability in tort, or any other legal theory.